

MACHINE ACCESORIES

Our range of machine related accessories is vast and only some have been covered in detail.

This section has been designed to mention some of the products and services available. These include: punches, dies and nipple pins, abrasives, automatic bottom cementing brushes, insole attaching fittings, perforating paper.

Other products which are available are: Releasants sprays, cutting pads, edge setting irons, filters, pneumatic bags, last pegs, scouring wheels and many more.

Please contact us should you require a product which is not listed in this catalogue.



Advent House
37 Church Lane
Ratby
Leicester
United Kingdom
LE6 06F
Tel: +44 (0)870 801 0910
Fax: +44 (0)870 801 0911
Email: contact@atlgb.com
Website: www.atlgb.com



MACHINE ACCESSORIES



MACHINE ACCESSORIES

Contents

PUNCHES, DIES and NIPPLE PINS.....	2
No.2 and No.3 Epoch Eyeleting Machines – Ordinary Eyeleting.....	2
Choosing the right Punches, Dies and Nipple Pins.....	3
Epoch No.2.....	3
Epoch No.3.....	3
Blind (Invisible) Eyeleting	4
No.3 Epoch Eyeleting Machine	4
Model C Eyeleting Machine.....	4
AUTOMATIC CEMENTING MACHINE BRUSHES.....	5
ABRASIVES.....	6
Which grade should you use?	6
Abrasive Belts for Upper Roughing and Scouring Machines (UUR).....	7
Abrasive Belt for Toe Scouring Attachment on Automatic Roughing Machines	7
Pre-Cut Strips	7
Abrasive Coils.....	7
INSOLE ATTACHING FITTINGS	8
Seat Fittings.....	8
Toe Fittings.....	8
PERFORATING PAPER.....	9

If you require any further information about these products, please contact us. See details at the front of this booklet.



MACHINE ACCESSORIES



PUNCHES, DIES and NIPPLE PINS

We sell punches, dies and nipple pins for use in both ordinary and blind (invisible) eyeleting. We provide a wide range of punches, dies and nipple pins for No.2 and No.3 Epoch and Model C eyeleting machines. For standard eyelets, e.g. Mogul, Rimmon, G336 we offer a made to order service to suit miscellaneous eyelets. Approximately a dozen sample eyelets are required to make made to order punches, dies and nipple pins.

No.2 and No.3 Epoch Eyeleting Machines – Ordinary Eyeleting

Description	Product Code
Punch (48) No.2/3 Epoch	AZX-221-11
Punch (Mogul) No.2/3 Epoch	AZX-221-12
Punch No.2/3 Epoch	AZX-221-14
Punch (00 Col) No.2/3 Epoch	AZX-221-17
Punch (ord) No.2/3 Epoch	AZX-221D-10
Punch No.2/3 Epoch	AZX-221D-5
Punch No.2/3 Epoch	AZX-221D-6
Punch (GW) No.2/3 Epoch	AZX-221D-7
Punch No.2/3 Epoch	AZX-221D-8
Punch (Rimmon) No.2/3 Epoch	AZX-221D-9
Top die (00 Col) No.2/3 Epoch	AZX-34A-00-COL
Top die No.48) No.2/3 Epoch	AZX-34A-48
Top die (Mogul) No.2/3 Epoch	AZX-34A-MOGUL
Top die (Rimmon) No.2/3 Epoch	AZX-34B-RIMMON
Bottom die (00 Col) No.2 Epoch only	AZX-44A-00-COL
Bottom die (No.48) No.2 Epoch only	AZX-44A-48
Bottom die (Mogul) Star No.2 Epoch only	AZX-44A-MOG-STAR
Bottom die (Mogul) No.2 Epoch only	AZX-44A-MOGUL
Bottom die (Rimmon) No.2 Epoch only	AZX-44A-RIMMON
Bottom die (Rim) Star No.2 Epoch only	AZX-44A-RIM-STAR
Bottom die (00 Col) No.3 Epoch only	AZX-628-00-COL
Bottom die (No.48) No.3 Epoch only	AZX-628-48
Bottom die (Mogul) Star No.3 Epoch only	AZX-628-MOGUL-ST
Bottom die (Mogul) No.3 Epoch only	AZX-628-MOGUL
Bottom die (Rimmon) No.3 Epoch only	AZX-628-RIMMON
Bottom die (Rim) Star No.3 Epoch only	AZX-628-RIM-STAR
Nipple pin (ord) No.2/3 Epoch	AZX-35-10
Nipple pin (No.48) No.2/3 Epoch	AZX-35-11
Nipple pin (Mogul) No.2/3 Epoch	AZX-35-12
Nipple pin (00 Col) No.2/3 Epoch	AZX-35-17
Nipple pin (Rimmon) No.2/3 Epoch	AZX-35-9

PUNCHES, DIES and NIPPLE PINS

Choosing the right Punches, Dies and Nipple Pins

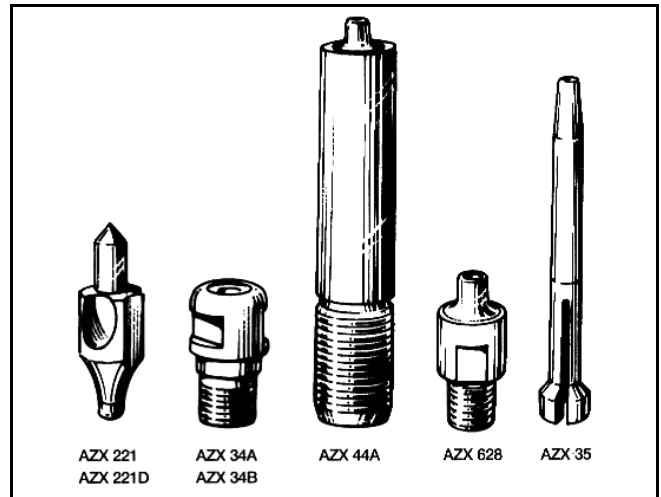

Epoch No.2

Eyelet Size	Punch	Nipple Pin	Top Die	Bottom Die (Rolled)	Bottom Die (Starred)
B Round/GW	AZX-221D-7	AZX-35-7*	AZX-34B-GW*	AZX-44A-AS-SAMPL*	AZX-44A-STAR*
A Round/Rimmon	AZX-221D-9	AZX-35-9	AZX-34B-RIMMON	AZX-44A-RIMMON	AZX-44A-RIM-STAR
O Round	AZX-221D-10	AZX-35-10*	AZX-34B-AS-SAMPL*	AZX-44A-AS-SAMPL*	AZX-44A-STAR*
No.48	AZX-221-11	AZX-35-11	AZX-34A-48*	AZX-44A-48*	AZX-44A-48-STAR*
AA Round/Mogul	AZX-221-12	AZX-35-12	AZX-34A-MOGUL	AZX-44A-MOGUL*	AZX-44A-MOG-STAR
OO Columbia	AZX-221-17	AZX-35-17	AZX-34A-00-COL	AZX-44A-00-COL*	AZX-44A-STAR*
Misc. Eyelets	Dependent on eyelet size	AZX-35-AS-SAMPLE*	AZX-34B-AS-SAMPL*	AZX-44A-AS-SAMPL*	AZX-44A-STAR*

*Made to order (sample eyelets required)

Epoch No.3

Eyelet Size	Punch	Nipple Pin	Top Die	Bottom Die (Rolled)	Bottom Die (Starred)
B Round/GW	AZX-221D-7	AZX-35-7*	AZX-34B-GW*	AZX-628-AS-SAMPL*	AZX-628-STAR*
A Round/Rimmon	AZX-221D-9	AZX-35-9	AZX-34B-RIMMON	AZX-628-RIMMON*	AZX-628-RIM-STAR*
O Round	AZX-221D-10	AZX-35-10*	AZX-34B-AS-SAMPL*	AZX-628-AS-SAMPL*	AZX-628-STAR*
No.48	AZX-221-11	AZX-35-11	AZX-34A-48*	AZX-628-AS-SAMPL*	AZX-628-48-STAR*
AA Round/Mogul	AZX-221-12	AZX-35-12	AZX-34A-MOGUL	AZX-628-MOGUL*	AZX-628-MOGUL-ST*
OO Columbia	AZX-221-17	AZX-35-17	AZX-34A-00-COL	AZX-628-AS-SAMPL*	AZX-628-STAR*
Misc. Eyelets	Dependent on eyelet size	AZX-35-AS-SAMPLE*	AZX-34B-AS-SAMPL*	AZX-628-AS-SAMPL*	AZX-628-STAR*

*Made to order (sample eyelets required)

PUNCHES, DIES and NIPPLE PINS

Blind (Invisible) Eyeleting

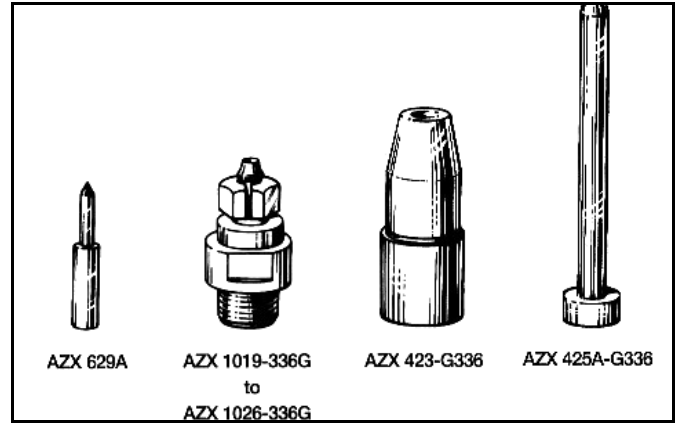

No.3 Epoch Eyeleting Machine

Description	Product Code
Punch and bottom set - No.3 Epoch	AZX-1023-336G
Punch and bottom set - No.3 Epoch	AZX-1026-336G
Upper die (G336) - No.3 Epoch	AZX-225-G336
Feed point - No.3 Epoch Eyeletter	AZX-629A

Model C Eyeleting Machine

Description	Product Code
Punch and top set light leather - Model C	AZX-1019-336G
Punch and top set heavy leather - Model C	AZX-1019A-336G
Punch and top set (synthetics) - Model C	AZX-1019B-336G
Bottom die - Model C Eyeletter	AZX-423-G336
Bottom set spindle - Model C	AZX-425A-G336

AUTOMATIC CEMENTING MACHINE BRUSHES

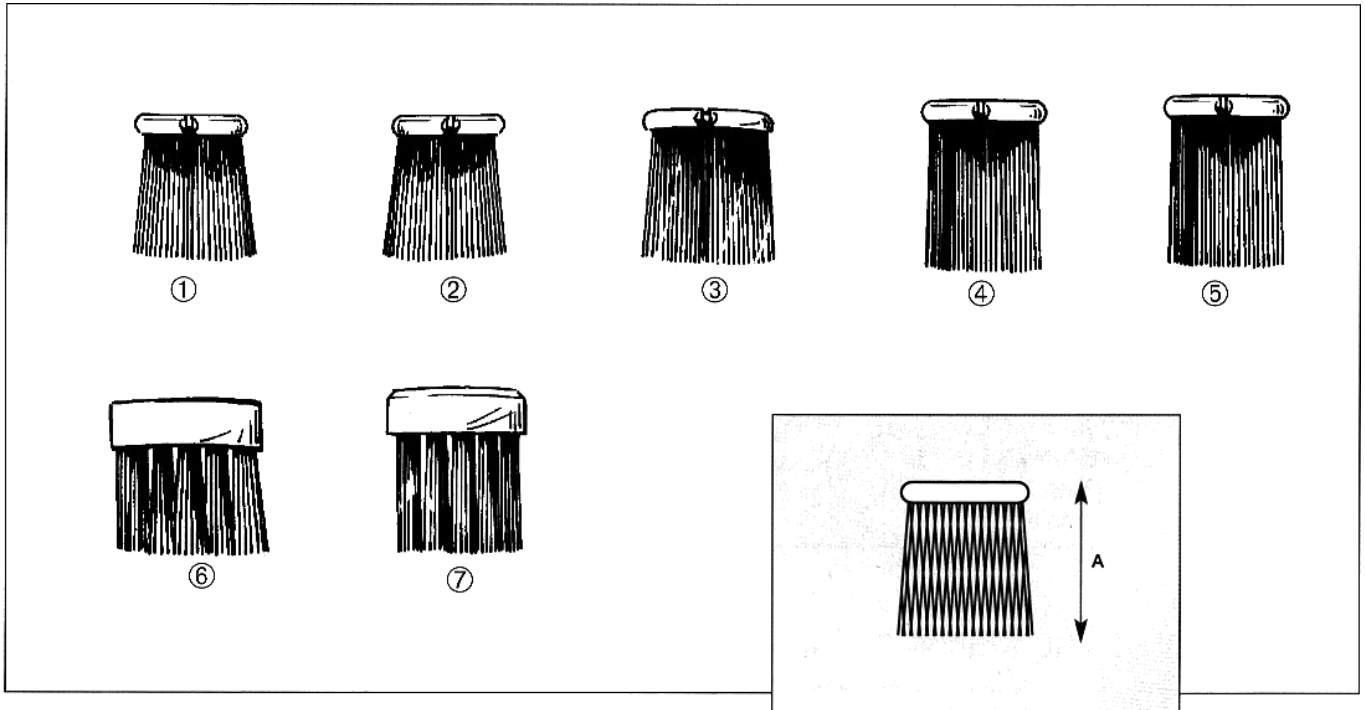

Description	Length A mm	Item No.	Product Code
Horse hair brush for solvent-based adhesive.	22	1	SAF-ABC-81
Pig bristle brush for solvent-based adhesive. High quality alternative to ABC-81.	22	2	SAF-ABC-81RD
Horse hair brush for solvent-based adhesive. High volume application.	22	3	SAF-ABC-355
Horse hair brush for solvent-based adhesive. High volume application. Also gives greater bristle spread.	25	4	SAF-355-LONG
Horse hair brush for solvent-based adhesive. Provides greater bristle spread.	25	5	SAF-ABC-374
Punch filled, horse hair brush for water-based adhesive.	22	6	SAF-ABC-378
Punch filled, horse hair brush for water-based and solvent-based adhesives.	25	7	SAF-ABC-386

ABRASIVES

The Advent Technologies range offers a wide selection of abrasives for all aspects of shoemaking.

Modern coated abrasives have synthetic backing materials. This results in a higher quality scour and an overall prolonged life. The abrasive minerals are technologically advanced to increase performance and ensure durability.

Our abrasives belts prove extremely economical as, once the grit is filled in one direction, they can be taken off the machine and reversed.

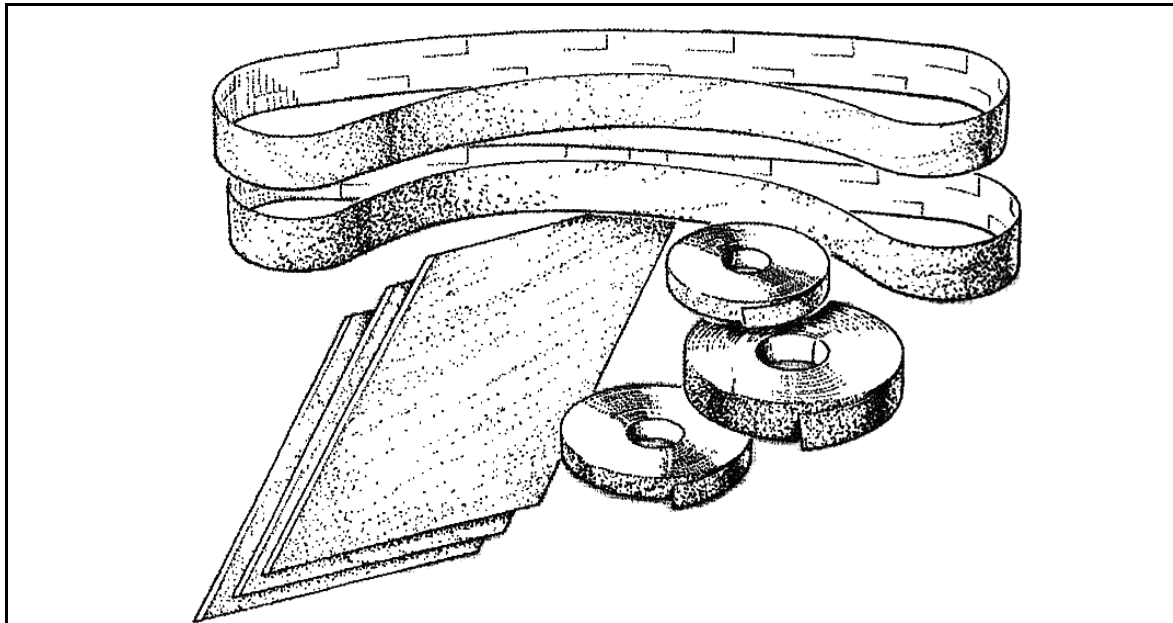

Which grade should you use?

Suggested Application	Product Code
Very fine scour, often used for shoe bottom scouring and buffing leather at the tannery.	P220 - P180
Medium scour, can be used for shoe bottom and heel scouring.	P150 - P100
Used as a rough scour preparation on shoe bottoms and heels before using a finer grit.	P80 - P60
Used for most types of upper roughing work, prior to cementing, including light leather, PVC, PU and Poromerics. P40 is used where only a light scour on the forepart is required.	P40 - P36
This grade is used for roughing medium to heavy upper leathers. It is also recommended for roughing leather with a high grease content.	P24



MACHINE ACCESSORIES



ABRASIVES

Abrasive Belts for Upper Roughing and Scouring Machines (UUR)

Suggested Application	Width mm	Length mm	Grit	Product Code
For use on No.2 Upper Roughing (UUR) and Scouring Machine.	100	2150	P24	BUZA-285A-24
	100	2150	P36	BUZA-285A-36

Suggested Application	Width mm	Length mm	Grit	Product Code
For use on No.3 & 4 Upper Roughing (UUR) and Scouring Machine.	100	2450	P24	BUZA-291A-24
	100	2450	P36	BUZA-291A-36

Abrasive Belt for Toe Scouring Attachment on Automatic Roughing Machines

Suggested Application	Width mm	Length mm	Grit	Product Code
For use on toe scouring attachment (MTS-101).	50	630	P24	BUZA-50X628-P24

Pre-Cut Strips

Suggested Application	Width mm	Length mm	Grit	Product Code
For use on Rex Rotary Pounding-Up Machine.	100	825	P24	BUZA-254-24

Abrasive Coils

Suggested Application	Width mm	Length mm	Grit	Product Code
For use on a variety of roughing and scouring machines.	32	25	P36	BUZA-293A-36
	32	25	P40	BUZA-293A-40
	32	25	P60	BUZA-293A-60
	32	25	P150	BUZA-293-150
	32	25	P180	BUZA-293-180
	38	50	P220	BUZA-294-220
	38	50	P24	BUZA-294A-24
	38	50	P36	BUZA-294A-36
	38	50	P100	BUZA-294A-100

INSOLE ATTACHING FITTINGS

Insole attaching fittings provide the shoe manufacturer with a means of attaching insoles without tacks, staples or tape. The lasts are equipped with a specially designed fittings positioned at the toe and seat, which holds the insole securely during the lasting operation.

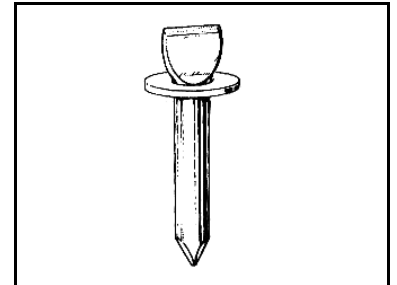

Seat Fittings

Suggested Application	Product Code
Used on men's footwear, safety, industrial and military boots, with 4 iron/2mm insoles or above.	SMUF-253A Standard seat
Used with very light women's and children's insoles.	SMUF-262A Shallow seat
Used with the above two items.	SMUF-254 Washer
Used on unplated lasts as a base for fittings.	SMUF-280 Washer

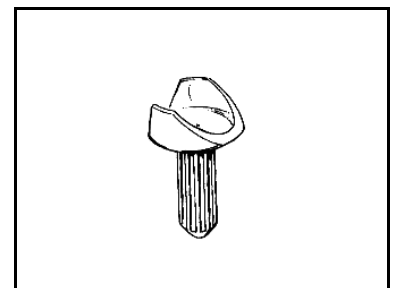

Toe Fittings

Suggested Application	Product Code
Used on men's footwear, safety, industrial and military boots, with 4 iron/2mm insoles or above.	SMUF-259 Deep toe
Used on ladies' fashion shoes or other footwear with insoles of 4 iron/2mm and less.	SMUF-258 Medium toe
Used on very light women's and children's insoles.	SMUF-260 Shallow toe

PERFORATING PAPER

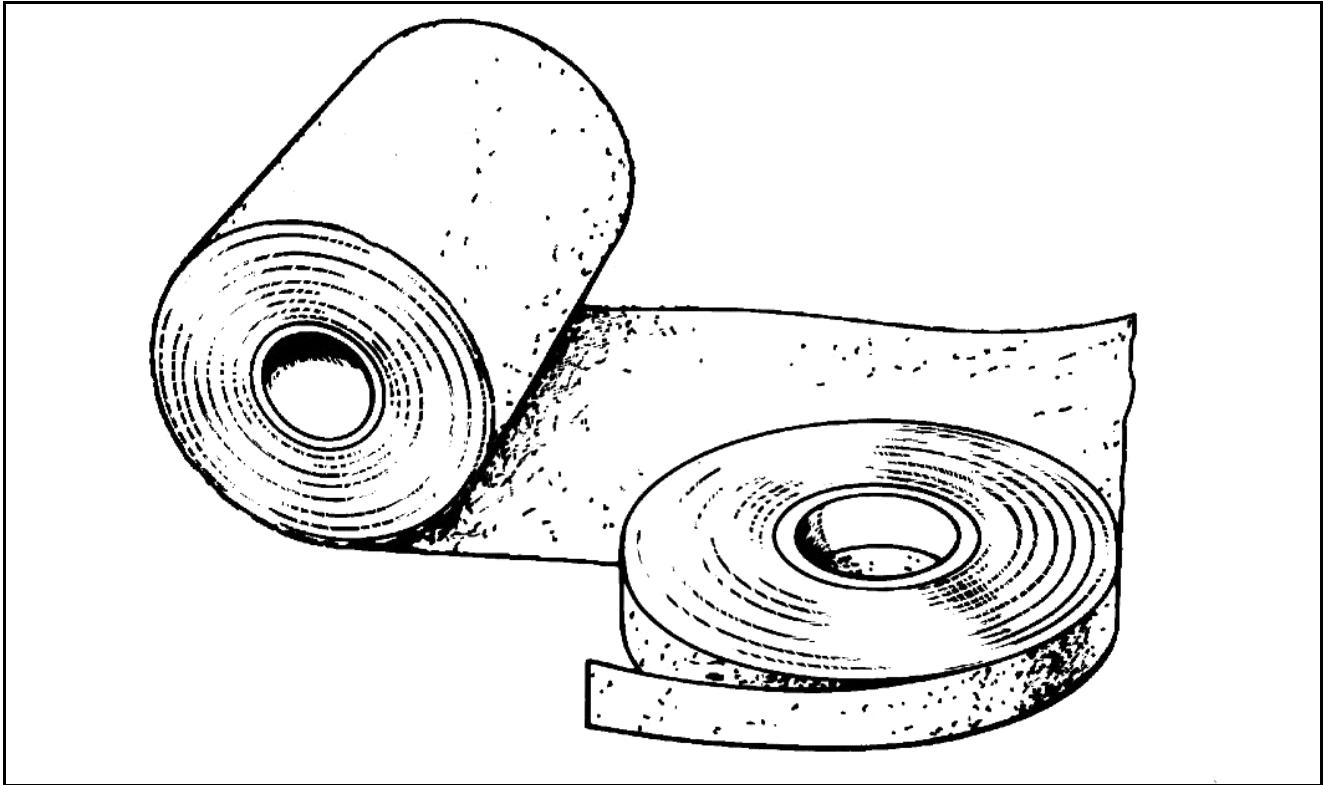

Perforating paper is thin shoe cutting board which is made from lightweight, extra hard rolled paper. It is used as a backing board in the shoe industry to protect and prolong the life of eyelet and perforating paper.

The following widths of perforating paper are available.

Width (")	Product Width (mm)	Code
$\frac{7}{16}$	11	AZX-1955
$\frac{3}{4}$	19	AZX-1957
3	75	AZX-1959
$4\frac{1}{2}$	115	AZX-1960
6	150	AZX-1962
7	175	AZX-1963
8	200	AZX-1965
10	250	AZX-1967
12	300	AZX-1968

The thickness of AZX-1955 and AZX-1957 is 0.45mm (0.18") and all other sizes are 0.50mm (0.20").