

GRINDSTONES

The use of grindstones and sharpening stones is widespread within the shoe factory. Their application ranges from cutter sharpening and edge profiling to sharpening skiving knives and roughing brushes.

Grinding stones are made from many different types of abrasive particles. These are selected according to the intended application. The bonding compound, which holds these particles together, is just as important as the grit itself, as both are subjected to tremendous strain during use.

These products undergo stringent tests at every stage of manufacture, from quality of the raw material selected, to the balance, safety and accuracy of the finished product against specification.

A full range of grindstones and sharpening stones are shown on the following pages where they have been grouped by application. For each, there is a concise description to help you choose the ideal product for your requirement.



Advent House
37 Church Lane
Ratby
Leicester
United Kingdom
LE6 06F
Tel: +44 (0)870 801 0910
Fax: +44 (0)870 801 0911
Email: contact@atlgb.com
Website: www.atlgb.com

GRINDSTONES

Contents

STONES for CUTTER SHARPENING2

STONES for EDGE PROFILING2

STONES for SHARPENING SKIVING KNIVES3

STONES for SHARPENING ROUGHING BRUSHES.....4

STONES for SHARPENING AUTOMATIC ROUGHING BRUSHES4

MISCELLANEOUS STONES5

If you require any further information about these products, please contact us. See details at the front of this booklet.

GRINDSTONES

STONES for CUTTER SHARPENING

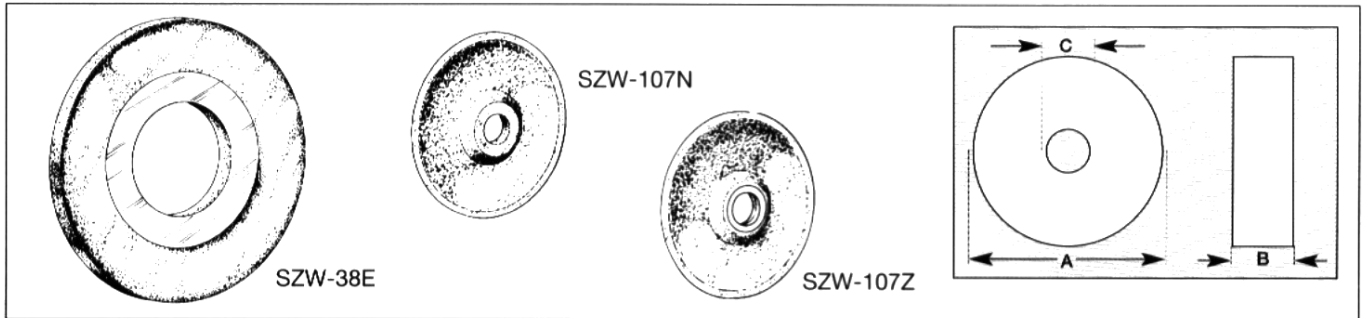

Description	Dimensions (mm)	Product Code
Glidden wheel for sharpening edge cutters. White Aloxite dished stone.	89.0 (A) 1.6 (B) 12.7 (C)	SZW-107N
Grindstone for sharpening Ultima Heel Cutters for No.3 Ultima Grinding Machine.	203.0 (A) 12.7 (B) 76.2 (C)	SZW-38E

STONES for EDGE PROFILING

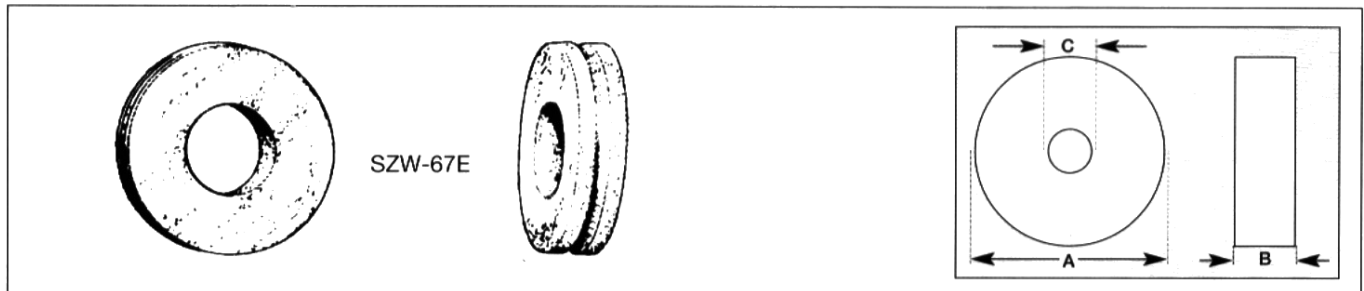

Description	Dimensions (mm)	Product Code
Profiled stone for Auto Edge Trimming Machines (5 iron).	42.9 (A) 9.5 (B) 19.0 (C)	SZW-67E-5-100W
Profiled stone for Auto Edge Trimming Machines (6 iron).	42.9 (A) 9.5 (B) 19.0 (C)	SZW-67E-6-100W
Profiled stone for Auto Edge Trimming Machines (8 iron).	42.9 (A) 9.5 (B) 19.0 (C)	SZW-67E-8-100W

GRINDSTONES

STONES for SHARPENING SKIVING KNIVES

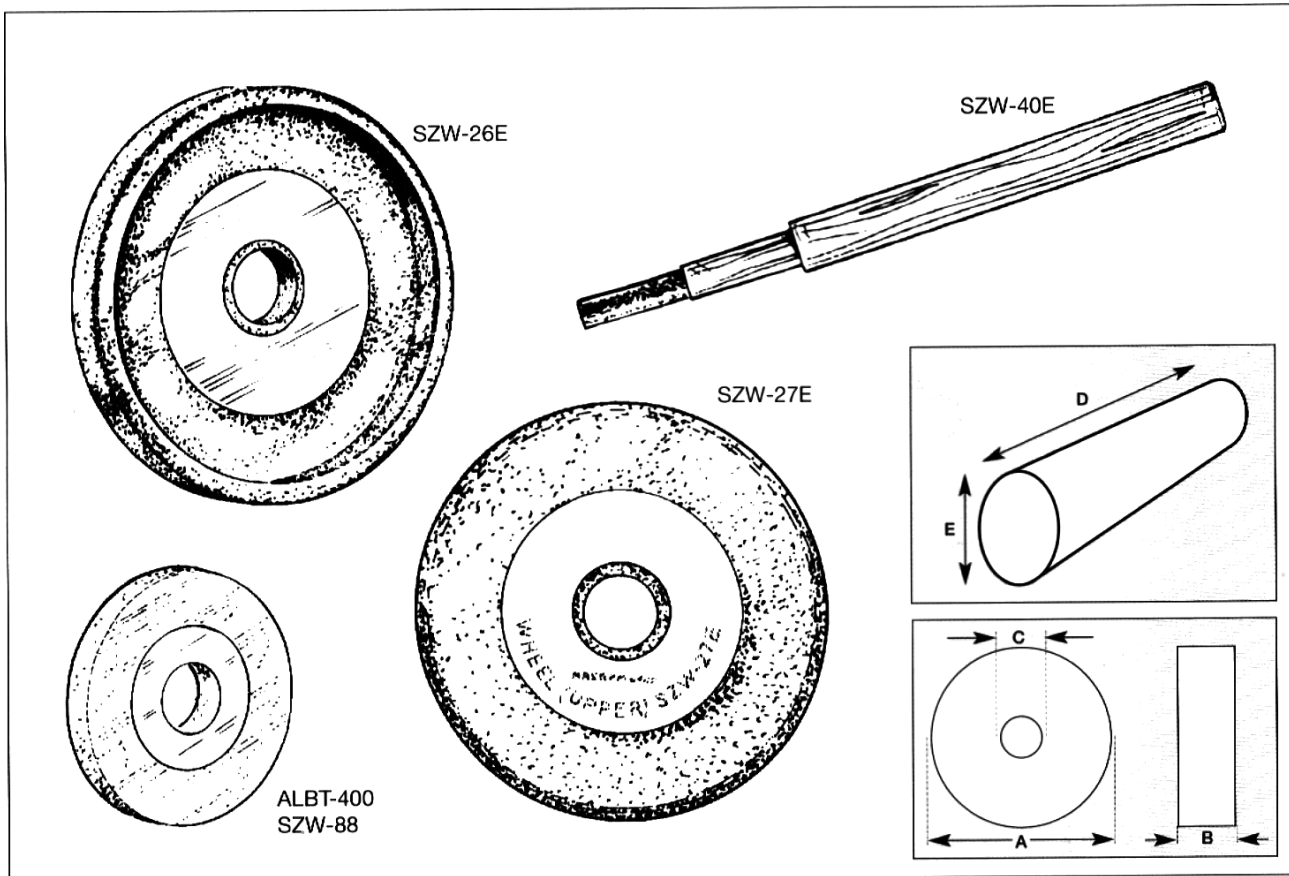

Description	Dimensions (mm)	Product Code
Sharpening stone (lower) for Marvel and No.9 Skiving Knife (KZG-447E).	127.0 (A) 12.7 (B) 22.2 (C)	SZW-26E
Sharpening stone (upper) for Marvel and No.9 Skiving Knife (KZG-447E).	127.0 (A) 12.7 (B) 22.2 (C)	SZW-27E
Dressing stick for sharpening the knife by hand on a No.9 Skiving Machine (KZG-447E).	203.0 (D) 19.0 (E)	SZW-40E
Sharpening stone for the bell knife (KZG-88-BELLKNIFE).	69.9 (A) 7.0 (B) 17.5 (C)	ALBT-400
Sharpening stone for the bell knife (KZG-88 BELLKNIFE). Recommended when skiving toe puffs and stiffeners. Harder than ALBT-400.	69.9 (A) 6.5 (B) 17.5 (C)	SZW-88

GRINDSTONES

STONES for SHARPENING ROUGHING BRUSHES

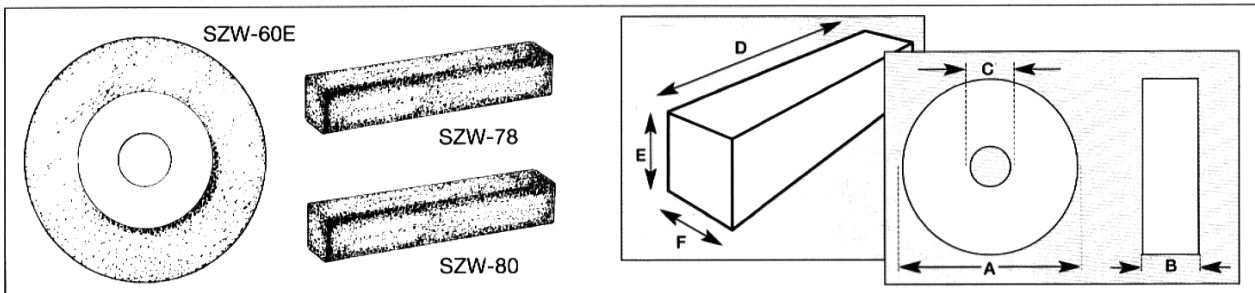

Description	Dimensions (mm)	Product Code
Sharpening stone for No.2/3/4 Upper Roughing and Scouring Machines (coarse).	152.4 (D) 25.4 (E) 25.4 (F)	SZW-78
Sharpening stone for No.2/3/4 Upper Roughing and Scouring Machines (fine).	152.4 (D) 25.4 (E) 25.4 (F)	SZW-80
Grinding wheel for No.3 Upper Roughing and Scouring Machine.	139.7 (A) 25.4 (B) 28.6 (C)	SZW-60E

STONES for SHARPENING AUTOMATIC ROUGHING BRUSHES

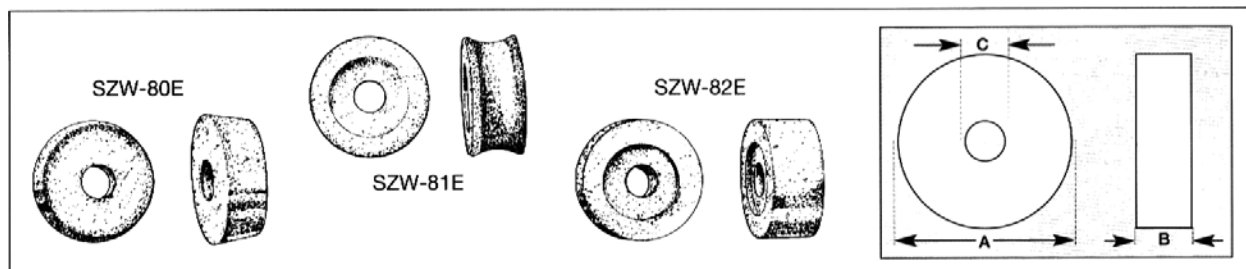

Description	Dimensions (mm)	Product Code
Grinding wheel for Automatic Roughing Machines.	69.9 (A) 25.4 (B) 19.0 (C)	SZW-80E
Recessed grinding wheel for Automatic Roughing Machines (concave face used for narrow-toed footwear).	69.9 (A) 31.7 (B) 19.0 (C)	SZW-81E
Recessed grinding wheel for Automatic Roughing Machines (flat face used for broad-toed footwear).	69.9 (A) 31.7 (B) 19.0 (C)	SZW-82E

GRINDSTONES

MISCELLANEOUS STONES

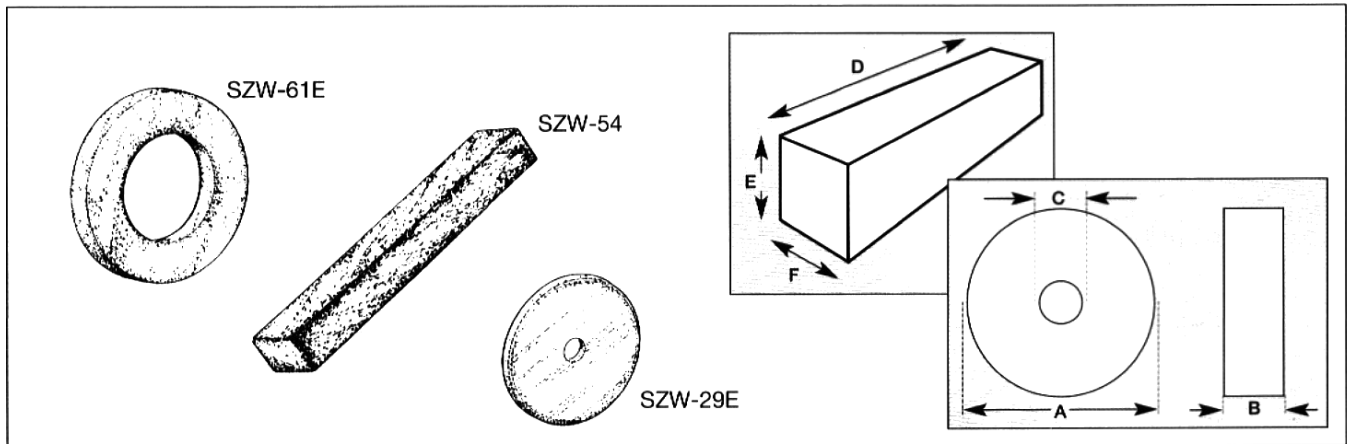

Description	Dimensions (mm)	Product Code
Sharpening wheel for No.6 Boothco and Model J Trimming Machines.	63.5 (A) 9.5 (B) 7.9 (C)	SZW-29E
Sharpening stone for No.2 Rapid Folding and Taping Machine.	69.9 (D) 9.5 (E) 15.8 (F)	SZW-54
Grinding wheel for No.3 Splitting Machine.	76.2 (A) 11.1 (B) 38.1 (C)	SZW-61E

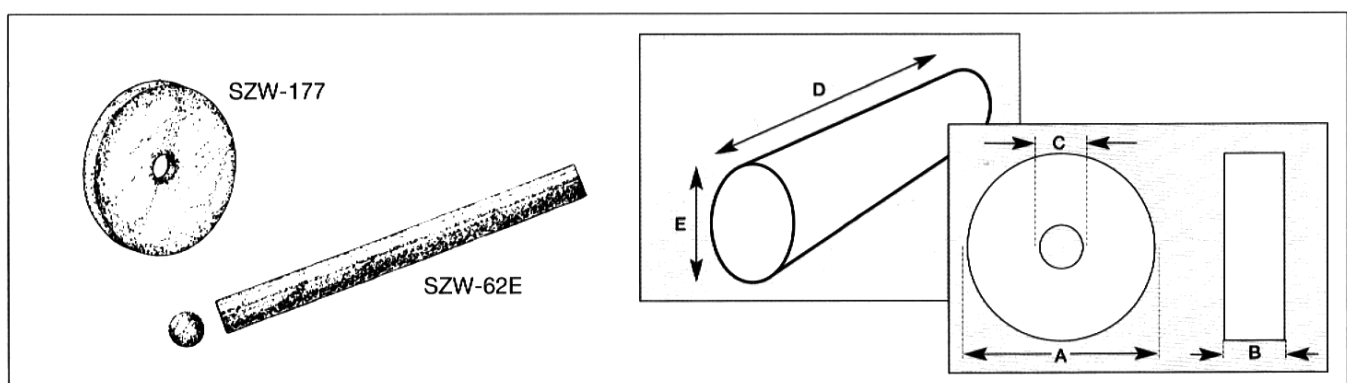

Description	Dimensions (mm)	Product Code
Dressing stick for No.3 Splitting Machine.	152.0 (D) 12.7 (E)	SZW-62E
Grinding wheel for No.5 Honing Device.	69.9 (A) 7.9 (B) 9.5 (C)	SZW-177